

B1 SCALA APRIBILE A DOPPIA RAMPA DOUBLE SIDED FOLDING STEP LADDER

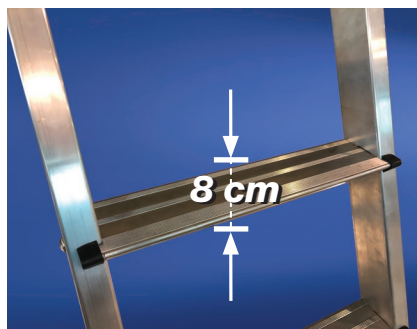

GRADINI PIANI / FLAT STEPS



GRADINI PIOLI / RUNGS

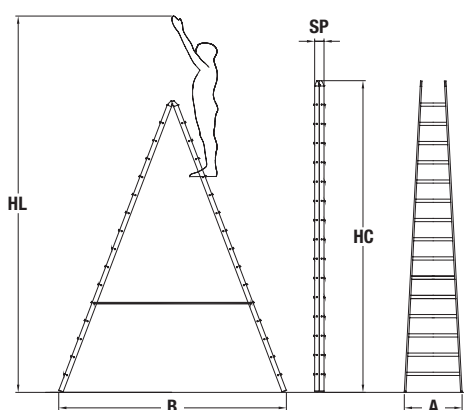

OPTIONAL

 Piattaforma ribaltabile
Folding platform

- 1** Robusti gradini rigati antiscivolo e antigiro fissati ai montanti della scala con viti autobloccanti (gradini sostituibili)
Sturdy non-slip striped steps fixed to the uprights of the ladder with self-locking screws (replaceable steps)
- 2** Cinghie di sicurezza
Safety straps
- 3** Piedi in gomma antiscivolo
Non-slip rubber feet
- 4** Montanti 6 x 2 cm
Uprights 6 x 2 cm

PIANI/STEPS N. Gradini No. Steps	HL cm	HC cm	Larghezza / Width cm	Spessore / Thickness cm	Volume m ³	Peso / Weight Kg
5	285	150	51	16	0,12	9
6	310	175	54	16	0,15	10
7	340	200	56	16	0,18	12
8	360	225	59	16	0,21	14
9	390	260	61	16	0,24	16
11	420	300	64	16	0,31	20
12	450	325	66	16	0,33	21
13	480	350	69	16	0,38	22
15	530	410	75	16	0,47	25

PIOLI / RUNGS N. Gradini No. Steps	HL cm	HC cm	Larghezza / Width cm	Spessore / Thickness cm	Volume m ³	Peso / Weight Kg
5	310	175	50	12	0,1	8
6	340	200	53	12	0,13	9
7	360	225	56	12	0,15	10
8	390	260	59	12	0,18	12
9	420	300	62	12	0,22	13
10	450	325	65	12	0,25	14
11	480	350	68	12	0,29	16
13	530	410	75	12	0,36	18